

Valve Regulated Lead Acid Battery

Discover[®] AGM Series VRLA Industrial Batteries provide superior high integrity and reliability for commercial, industrial, and private applications. The maintenance-free Valve Regulated Lead Acid (VRLA) construction make Discover[®] Standard AGM Series Batteries the definitive choice for mobility and Home Medical Equipment (HME), solar and renewable energy, electronics and security, marine and RV, and utility applications.

MECHANICAL DRAWINGS

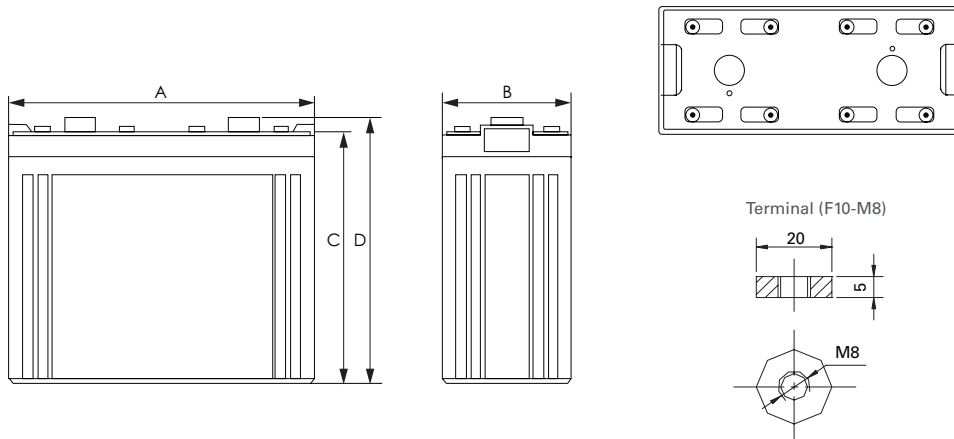

MECHANICAL SPECIFICATIONS

Length (A)	18.7 in	475 mm
Width (B)	6.89 in	175 mm
Height (C)	13.0 in	330 mm
Total Height (D)	14.4 in	367 mm
Weight	134.2 lbs	61 kgs
Terminal (Opt'l)	F10	
Cells	1	
Electrolyte	AGM	

TERMINAL TORQUE: Please refer to our document, located in the Resources webpage (discoverbattery.com/resources).

*CAUTION: Extra considerations must be given to depths of discharge, operating voltages and currents when designing systems for use at maximum temperatures.

ELECTRICAL SPECIFICATIONS

Voltage	2 V
Internal Resistance	0.5 mΩ
Short Circuit 20°C (68°F)	-
20 HR	1075Ah
10 HR	1000 Ah
5 HR	890 Ah
1 HR	615 Ah
15 MIN	-
Charge Temperature	-10°C (14°F) to 50°C (122°F)
Discharge Temperature	-20°C (-4°F) to 50°C (122°F)
Maximum Discharge*	-40°C (-40°F) to 60°C (140°F)

DISCHARGE CONSTANT CURRENT (AMPERES AT 25°C/77°F)

End Point V/C	5 MIN	10 MIN	15 MIN	30 MIN	1 HR	3 HR	5 HR	10 HR	20 HR
1.60V	-	1850	1405	1060	615	260	192	107	-
1.65V	-	1750	1335	1013	598	256	188	106	-
1.70V	-	1650	1265	964	578	252	183	104	-
1.75V	-	1550	1195	915	550	248	178	102	-
1.80V	-	1450	1123	863	530	243	172	100	-

DISCHARGE CONSTANT POWER (WATTS AT 25°C/ 77°F)

End Point V/C	5 MIN	10 MIN	15 MIN	30 MIN	45 MIN	1 HR	2 HR	3 HR	5 HR
1.60V	-	2965	2421	1804	1360	1114	720	522	360
1.65V	-	2793	2290	1713	1298	1067	702	507	354
1.70V	-	2620	2158	1621	1233	1018	688	497	348
1.75V	-	2447	2024	1527	1166	967	676	488	341
1.80V	-	2278	1890	1432	1099	915	661	476	335

BENEFITS & FEATURES

Tank formed lead-tin-calcium plates deliver consistent dependable performance and promote long life.

Maintenance-free technology.

99% gas recombination for extended life in float applications.

Multiple terminal, configuration options and carrying handles available with most models.

Classified as a non-spillable battery and is not restricted for transportation by:

- Air (IATA/ICAO provision 67)
- Ground (STB, DOT-CFR-HMR49)
- Water (per IMDG amendment 27)

Flame retardant ABS case and cover with UL94 V0 rating available.

UL924 recognized flame arresting low pressure safety vents.

98% recyclable.

Up to 12 year design life in float service.

CERTIFIED QUALITY

Designed in accordance with and published in compliance with applicable BCI, IEC and BS EN standards, including:

- IEC60896-21/22
- BS EN 60254-1:2005
- AS/NZS 4029.2:2000 BS EN 60254-1:2005 (MOD)

Discover[®] and its facilities and products are certified to multiple standards:

- ISO, UL, QS, and TUV standards
- ETTS Germany
- Euro Bat classification for Environmental Stewardship Standards



CHARGE AND DISCHARGE

Max Charge / Discharge Currents	Peak (5 seconds)	Peak (10 seconds)	Max Continuous
Charge	1c20	0.75c20	0.25c20
Discharge	15c20	10c20	0.5c20

Float (Stand-By) Use: Hold a constant voltage of 2.25vpc to 2.30vpc continuously. When held at this voltage, the battery will seek its own current level and maintain itself in a fully charged condition.

Cyclic Use: Limit initial currents to 0.25C20 amps. Charge until battery voltage reaches 2.40 to 2.45vpc. Hold at 2.40 to 2.45vpc until current drops to under 0.01C20 amps. Battery is fully charged under these conditions, and charger should be disconnected or switched to "float" voltage.

Temperature Coefficient: Adjust charging voltage to +/- 0.005vpc (C, 0.003vpc/F) from 25°C (77°F).

DISCHARGE CHARACTERISTICS (20°C/68°F)

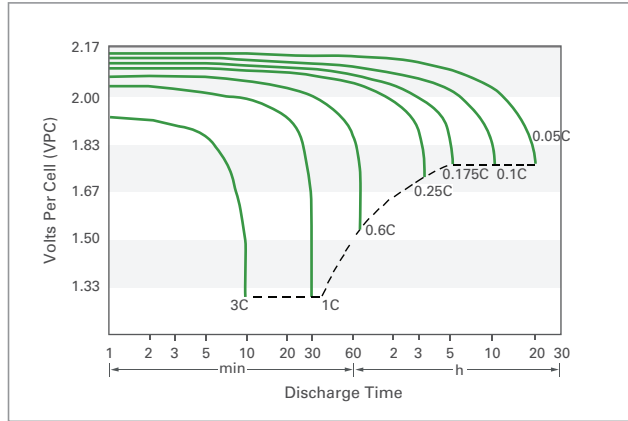

SELF-DISCHARGE CHARACTERISTICS

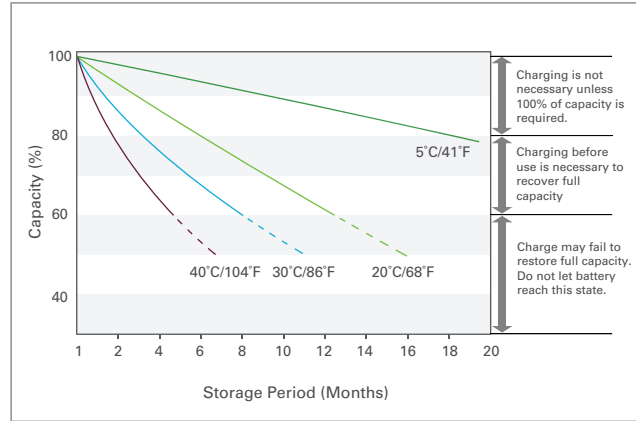

LIFE CHARACTERISTICS IN STAND-BY USE

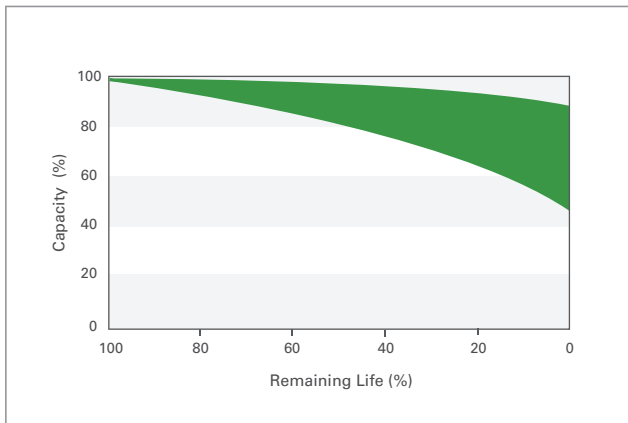

LIFE CHARACTERISTICS IN CYCLIC USE (CYCLIC MODELS ONLY)

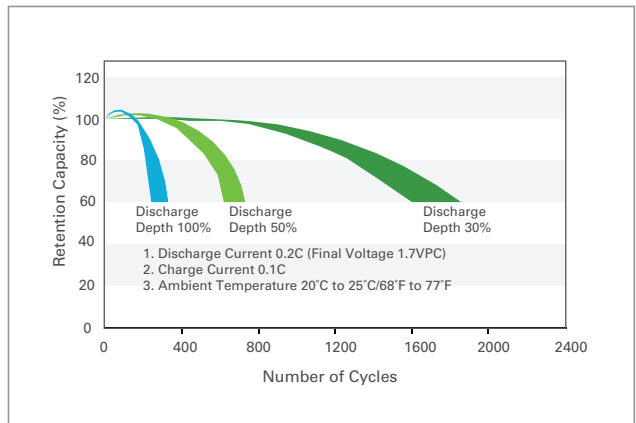

TEMPERATURE EFFECTS ON CAPACITY

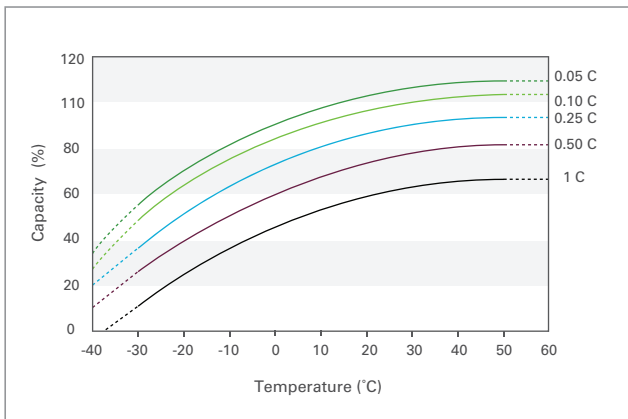

TEMPERATURE EFFECTS ON FLOAT LIFE

