

Valve Regulated Lead Acid Battery

Discover[®] AGM Series VRLA Industrial Batteries provide superior high integrity and reliability for commercial, industrial, and private applications. The maintenance-free Valve Regulated Lead Acid (VRLA) construction make Discover[®] Standard AGM Series Batteries the definitive choice for mobility and Home Medical Equipment (HME), solar and renewable energy, electronics and security, marine and RV, and utility applications.

MECHANICAL DRAWINGS

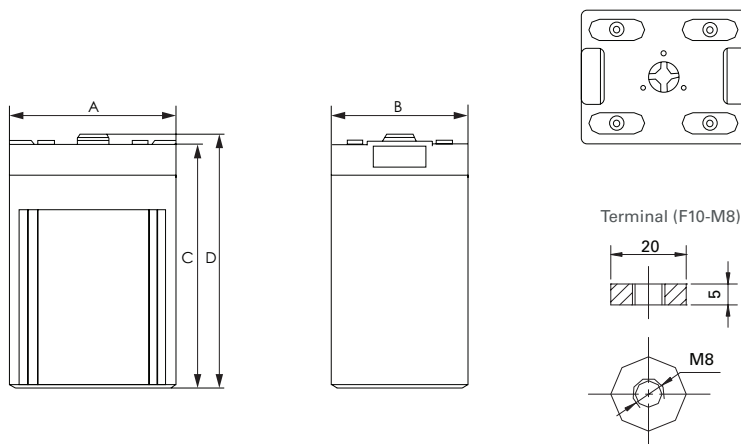

MECHANICAL SPECIFICATIONS

Length (A)	8.27 in	210 mm
Width (B)	6.93 in	176 mm
Height (C)	13.0 in	330 mm
Total Height (D)	14.4 in	367 mm
Weight	56.1 lbs	25.5 kgs
Terminal (Opt'l)	F10	
Cells	1	
Electrolyte	AGM	

TERMINAL TORQUE: Please refer to our document, located in the Resources webpage (discoverbattery.com/resources).

*CAUTION: Extra considerations must be given to depths of discharge, operating voltages and currents when designing systems for use at maximum temperatures.

ELECTRICAL SPECIFICATIONS

Voltage	2 V
Internal Resistance	-
Short Circuit 20°C (68°F)	-
20 HR	430 Ah
10 HR	400 Ah
5 HR	350 Ah
1 HR	245 Ah
15 MIN	-
Charge Temperature	-10°C (14°F) to 50°C (122°F)
Discharge Temperature	-20°C (-4°F) to 50°C (122°F)
Maximum Discharge*	-40°C (-40°F) to 60°C (140°F)

DISCHARGE CONSTANT CURRENT (AMPERES AT 25°C/77°F)

End Point V/C	5 MIN	10 MIN	15 MIN	30 MIN	1 HR	3 HR	5 HR	10 HR	20 HR
1.60V	-	732	587	424	245	114	75.5	43.0	-
1.65V	-	694	559	405	236	110	73.8	42.4	-
1.70V	-	654	530	385	227	106	71.8	41.7	-
1.75V	-	614	500	365	217	102	70.0	40.9	-
1.80V	-	573	470	344	206	98.0	67.0	40.0	-

DISCHARGE CONSTANT POWER (WATTS AT 25°C/ 77°F)

End Point V/C	5 MIN	10 MIN	15 MIN	30 MIN	45 MIN	1 HR	2 HR	3 HR	5 HR
1.60V	-	1285	912	740	643	495	311	215	140
1.65V	-	1210	863	703	612	473	288	210	138
1.70V	-	1135	813	665	578	452	272	204	135
1.75V	-	1061	763	625	545	427	262	198	132
1.80V	-	987	713	585	511	403	246	188	125

BENEFITS & FEATURES

Tank formed lead-tin-calcium plates deliver consistent dependable performance and promote long life.

Maintenance-free technology.

99% gas recombination for extended life in float applications.

Multiple terminal, configuration options and carrying handles available with most models.

Classified as a non-spillable battery and is not restricted for transportation by:

- Air (IATA/ICAO provision 67)
- Ground (STB, DOT-CFR-HMR49)
- Water (per IMDG amendment 27)

Flame retardant ABS case and cover with UL94 V0 rating available.

UL924 recognized flame arresting low pressure safety vents.

98% recyclable.

Up to 12 year design life in float service.

CERTIFIED QUALITY

Designed in accordance with and published in compliance with applicable BCI, IEC and BS EN standards, including:

- IEC60896-21/22
- BS EN 60254-1:2005
- AS/NZS 4029.2:2000 BS EN 60254-1:2005 (MOD)

Discover[®] and its facilities and products are certified to multiple standards:

- ISO, UL, QS, and TUV standards
- ETTS Germany
- Euro Bat classification for Environmental Stewardship Standards



CHARGE AND DISCHARGE

Max Charge / Discharge Currents	Peak (5 seconds)	Peak (10 seconds)	Max Continuous
Charge	1c20	0.75c20	0.25c20
Discharge	15c20	10c20	0.5c20

Float (Stand-By) Use: Hold a constant voltage of 2.25vpc to 2.30vpc continuously. When held at this voltage, the battery will seek its own current level and maintain itself in a fully charged condition.

Cyclic Use: Limit initial currents to 0.25C20 amps. Charge until battery voltage reaches 2.40 to 2.45vpc. Hold at 2.40 to 2.45vpc until current drops to under 0.01C20 amps. Battery is fully charged under these conditions, and charger should be disconnected or switched to "float" voltage.

Temperature Coefficient: Adjust charging voltage to +/- 0.005vpc (C, 0.003vpc/F) from 25°C (77°F).

DISCHARGE CHARACTERISTICS (20°C/68°F)

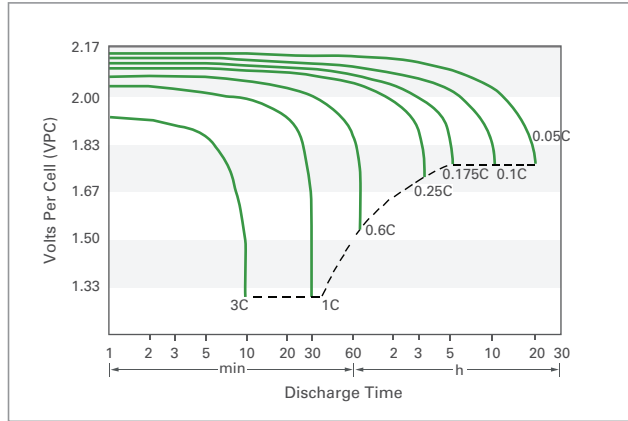

SELF-DISCHARGE CHARACTERISTICS

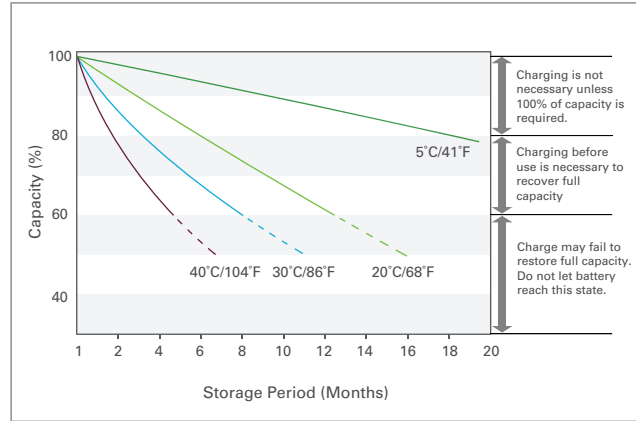

LIFE CHARACTERISTICS IN STAND-BY USE

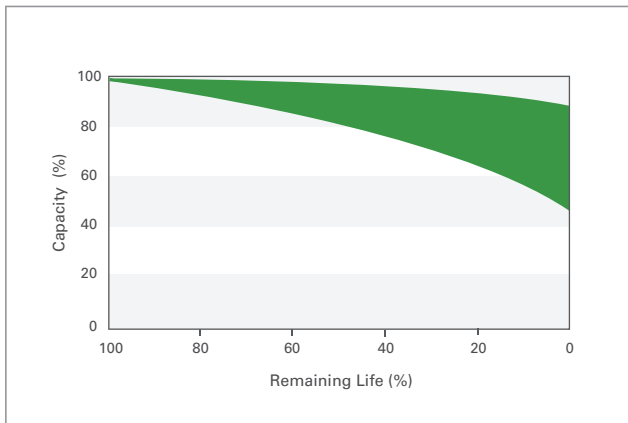

LIFE CHARACTERISTICS IN CYCLIC USE (CYCLIC MODELS ONLY)

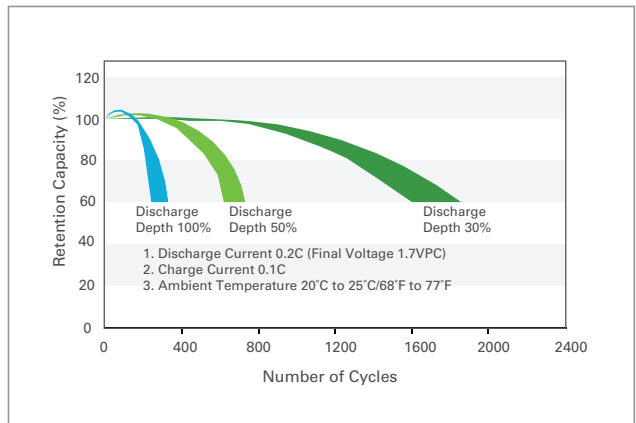

TEMPERATURE EFFECTS ON CAPACITY

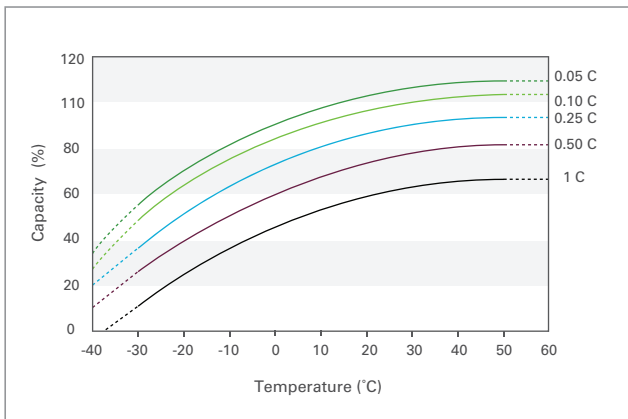

TEMPERATURE EFFECTS ON FLOAT LIFE

